

INSTRUCTIONS:

Model: SBH-101 Fixture

Read all instructions before installing.
Disconnect power before installing or re-lamping.

Overview: Fixtures are designed for use on WAC Linear system and are not compatible with other brands.

Lamp: T3 ¼" Xenon, (not tungsten halogen), rigid loop 12V/24V, clear or frosted. Visit our web site www.waclighting.com for replacement lamp information
To install lamp, simply push the base of the lamp into the socket of the fixture.

Installing fixtures:

Place the fixture contacts fully into the track channel and twist the fixture 90°. Fixtures are not polarized and may be turned in either direction. The fixture should feel tight in the track once installed.

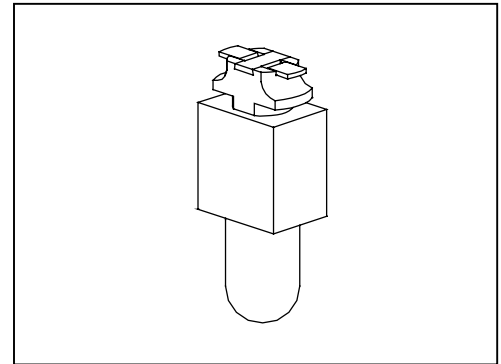

W • A • C | LIGHTING

www.waclighting.com

615 South Street, Garden City, NY 11530
Tel: (516) 515-5000 Fax: (516) 516-5050

168 Brea Canyon Road, City of Industry, CA 91789
Tel: (909) 468-1848 Fax: (909) 468-9958

12/18/02 REV