

# VAMP - model: HID202A

## Track System Luminaires

# WAC LIGHTING

Responsible Lighting®

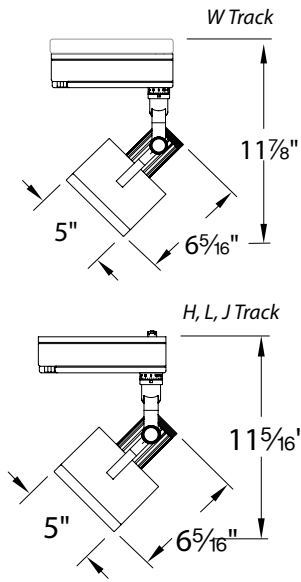

Fixture Type:

Catalog Number:

Project:

Location:

### PRODUCT DESCRIPTION

15° - 30° Adjustable beam angle metal halide fixture.

### FEATURES

- Accepts up to 3 filter lenses and 1 accessory
- Energy efficient high power factor electronic ballast.
- 350° horizontal rotation and 90° vertical aiming.
- Spring lock horizontal adjustment & push button vertical aiming w/ indexing scales
- Provides a cost effective lamping solution.
- Reflectors are integral to the fixture, assuring lighting design consistency.
- 5 year WAC Lighting product warranty.

### SPECIFICATIONS

**Construction:** Die-cast aluminum fixture, cap ring and check ring. Clear 3/8 inch tempered glass lens included.

**Finish:** Available in Black powder coat (**BK**), White powder coat (**WT**), or Platinum anodized (**PT**) finishes

**Lamp:** HID CDM T4, 20W/39W/70W (order separately).

**Standards:** UL & cUL listed

### ORDER NUMBER

Track Type	System	Model#	Power	Finish
H Track	HTK	120V	20E 20W 39E 39W 70E 70W	BK Black
L Track	LTK	120V		WT White
J/J2 Track	JTK	120V		
W Track	WTK	120V		BK Black
	WHK	277V		PT Platinum WT White

- **HID202A** -  -

Example: **WTK-HID202A-39E-WT**

	120V	20W	39W	70W
ANSI #		M156	M130	M98 / 139
Line Current		0.20A	0.38A	0.64A
Input Power		23W	45W	77W
Input Voltage		120V	120V	120V
Power Factor		>90%	>90%	>90%
Sound Rating		A	A	A

	277V	20W	39W	70W
ANSI #		M156	M130	M98 / 139
Line Current		0.093A	0.165A	0.286A
Input Power		23W	45W	77W
Input Voltage		277V	277V	277V
Power Factor		>90%	>90%	>90%
Sound Rating		A	A	A

### LENSES AND ACCESSORIES

Color Lens LENS-111	AMB	Amber	UV Filter Lens	LENS-111-UVF
	BLU	Blue	Frosted Lens	LENS-111-FR
	GRN	Green	Spread Lens	LENS-111-SPR
	RED	Red	Beam Elongating	LENS-111-BEL
	YEL	Yellow	Cross Louver	LENS-111-CRL
			Honeycomb	LENS-111-HCL
		Snoot	LENS-111-SNOOT	

### FINISHES



### WAC Lighting

www.waclighting.com

Phone (800) 526.2588 • Fax (800) 526.2585

### Headquarters/Eastern Distribution Center

44 Harbor Park Drive • Port Washington, NY 11050

Phone (516) 515.5000 • Fax (516) 515.5050

### Western Distribution Center

1750 Archibald Avenue • Ontario, CA 91760

Phone (800) 526.2588 • Fax (800) 526.2585